



WASTE CONTROL INTERNATIONAL

60" Vertical Baler

bales all grades of paper, plastic, and metals



420 Main Avenue • Neche, North Dakota 58265
701.886.7630 • Toll Free: 1.866.417.8711 • Fax: 701.886.7649
wastecontrolinternational.com

60" Vertical Baler Supplied By Waste Control International

The 60-inch Vertical Baler supplied by Waste Control International frees up valuable floor space. This tough-built baler not only keeps your work area clean, it can earn you money. Create a new revenue stream, or at least slow down cash outflow, by baling your discards like paper, plastic, and metals instead of having to pay to have them removed.

SPECIFICATIONS

PERFORMANCE

Nominal Bale Size	60" x 30" x 48"
Bale Weight	Up to 1000 lbs OCC
Average Cycle Time	37 Seconds
Loading Height	49.6"
Ejector System	Semi-Automatic
Compact Force	56,548 lbs
Approx. Baler Shipping Weight	4200 lbs

HYDRAULIC/ELECTRICAL

Motor	15 hp
Voltage 3 Phase	208, 230, 480
Pump	15 GPM
Normal System Pressure	2,000 PSI
Cylinder Bore	6"
Cylinder Stroke	48"
Hydraulic Tank Capacity	22 Gallons

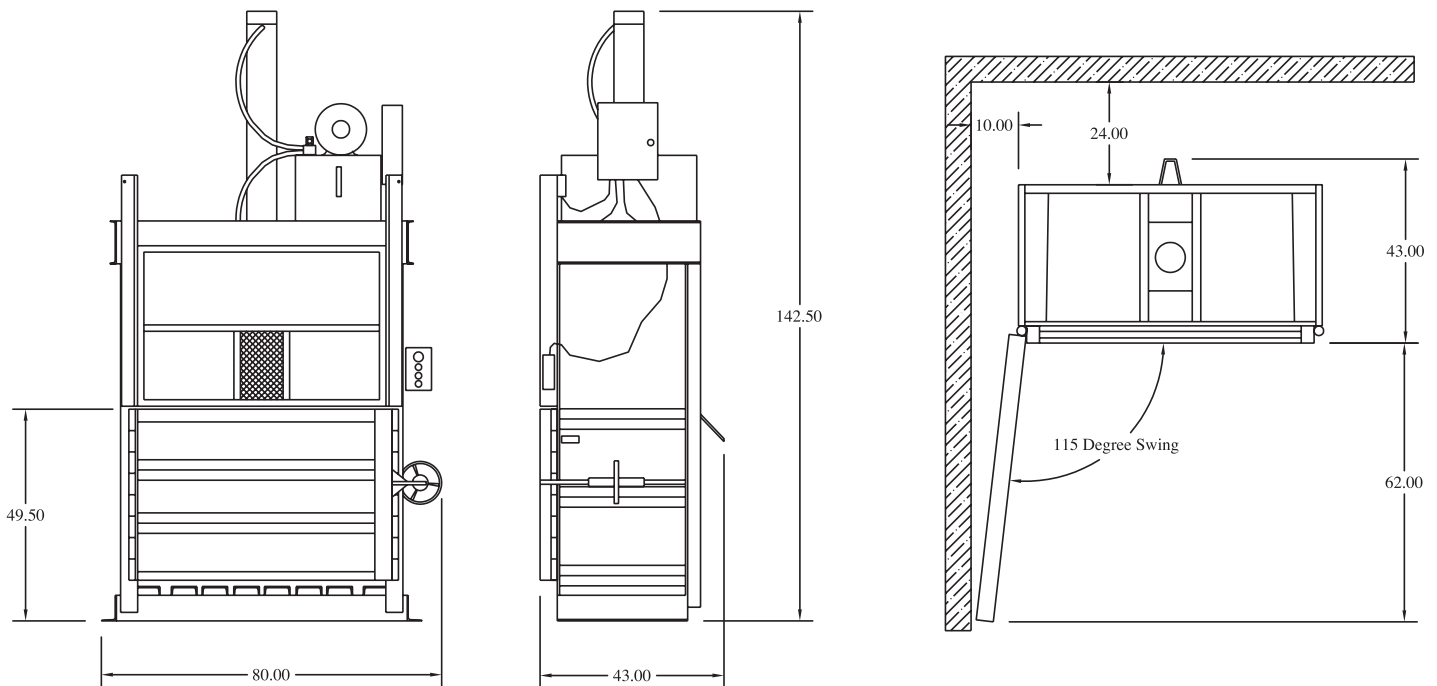

**Put the power of this 60-inch Vertical Baler
to work for you – contact Waste Control International today!**

1.866.417.8711